

TR-151 Vehicle/ Asset Tracker

User's Manual

V0.5



Document History

Status	Version	Date	Comment	Audience
Approved	0.1.0	02/09/09	Document Creation	Public

© 2009 Globalsat Technology Corporation/USGlobalsat, Inc. All rights reserved. The Globalsat logo is a trademark of Globalsat Corporation. Windows is a register trademark of Microsoft Corporation. Acrobat is a registered trademark of Adobe Systems Incorporated. Mac is a registered trademark of the Apple Corporation. All other trademarks or registered trademarks are acknowledged as the exclusive property of their respective owners.

All rights reserved. No part of this manual may be reproduced, transmitted, copied, or stored in any storage medium, for any purpose, without prior written consent from Globalsat Technology Corporation or USGlobalsat, Inc. Globalsat/USGlobalsat hereby grants the right to download one (1) copy of this manual onto a hard drive for personal use. This manual is copyrighted and may contain proprietary information that is subject to change without notice.

TABLE OF CONTENTS

1. Warning	4
2. Welcome	5
3. Introduction and Features	6
3.1 Introduction	6
3.2 LED Indicators.....	7
4. Device Operation	8
4.1 Device charging.....	8
4.2 SIM card and Battery Installation.....	9
4.3 Power.....	12
4.4 Emergency button	12
5. Safety Information	13
6. Limited Warranty	13
7. FCC Notices	18

1. Warning



USE RESPONSIBLY. READ ALL INSTRUCTIONS AND SAFETY INFORMATION BEFORE USE TO AVOID INJURY.

Globalsat Technology Corporation / USGlobalsat, Inc. will not accept any responsibility whatsoever for accidents resulting from failure to observe common sense precautions. Your personal judgment, traffic regulations, and common sense must always take precedence over any directions produced by GPS receiver or the mapping software.

WARNING: Be certain GPS receiver is secure and does not interfere with driving visibility and safety.

It is your responsibility as the vehicle operator to securely place the GPS unit and antenna so that they will not interfere with driving and prevent operations of any safety device, i.e. vehicle's airbag. Do not mount the devices in a place where the driver or passengers may receive injury during vehicle operation or collision. For your safety, take care to route all cables away from shifters, pedals, accessory controls and mechanisms.

WARNING: Drive safely and use common sense.

It is your responsibility as the vehicle operator to drive safely, observe all traffic rules and above all use your own personal judgment while driving. If you feel that a route suggested by the navigation software instructs you to perform an unsafe or illegal maneuver, places you in an unsafe situation, or routes you into an area which you consider unsafe, do not follow the instructions.

WARNING: Keep your eyes on the road.

It is your responsibility as the vehicle operator to keep your eyes on the road and be an alert driver at all times, especially when the vehicle is moving. The vehicle's operator should not be distracted by the navigation equipment or software. Should there be a distraction with the ability to drive responsibly, please turn off the device. Should you want to look at the display for a prolonged time, park the car safely, while following all traffic regulations before looking at the display.

WARNING: TO REDUCE FIRE OR SHOCK HAZARDD RISK, DO NOT EXPOSE PRODUCT TO RAIN OR MOISTURE. DO NOT REMOVE ENCLOSURE, THERE IS NO USER INTERNAL SERVICEABLE PARTS. REFER SERVICING TO QUALIFIED PERSONNEL ONLY.

2. Welcome

Thank you for purchasing the TR151 Vehicle/ Asset Tracker. The TR151 Vehicle/ Asset Tracker is a compact and portable tracking device, allowing flexibility to equip the unit to any vehicle with ease. In addition to its tracking abilities, the unit incorporates a wide array of custom configurations for users with unique needs. In result, the TR-151 tracker's versatility can be used for many tracking applications.

3. Introduction and Features

3.1 Introduction

TR-151 is a durable and water resistant GPS/GSM/GPRS tracker. In which, it can be install TR-151 on vehicles or assets for tracking with a free web service to track vehicles or assets remotely. Allowing the tracker to communicate via SMS, with location (longitude and latitude) information to user's cell phone. All performed from a GSM network or to personal computer via an internet network. The TR-151 is equipped with a high capacity Li-Ion battery designed for extensive operation times. The TR-151 includes an SOS button for emergency assistance. The TR-151 is very simple to install and hide in a vehicle to perform tracking. In ideal applications, TR-151 is for vehicle tracking and equipment/assets monitoring.

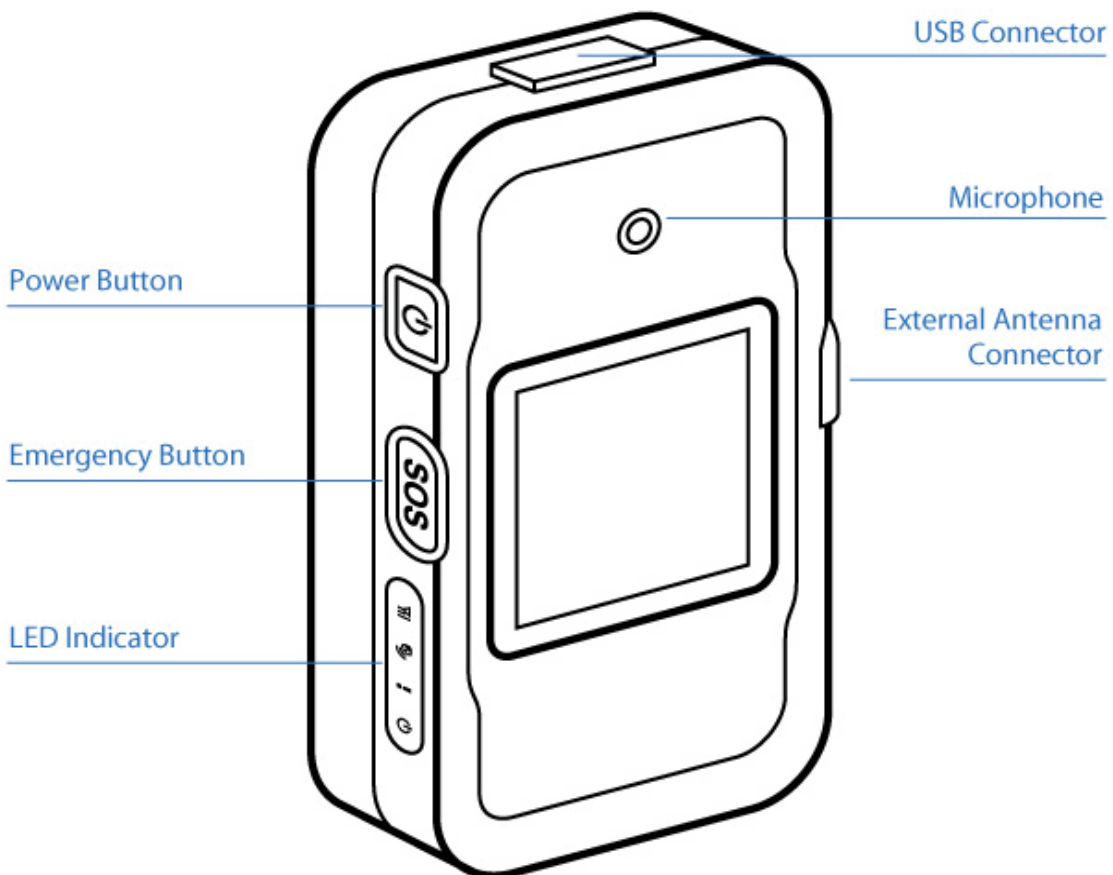

3. Introduction and Features (Continued)

3.2 LED Indicators

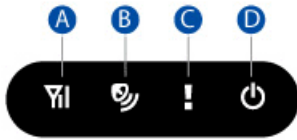

GSM LED

LED	Blink Quickly (Once per second)	Blink Slowly (Once every 3 seconds)	Off
State	No SIM card inserted TR-151 is searching GSM network	SIM card is registered to GSM network. TR-151 is sending data to GSM network	TR-151 is in standby mode

GPS LED

LED	Keeps On	Blink Slowly (Once every 3 seconds)	Off
State	TR-151 has not received a GPS fix TR-151 is attempting to attain a GPS fix	TR-151 has attained a GPS fix	TR-151 is in standby mode

Status LED

LED	Keeps On	Off	Blink			
			1 time	2 times	3 times	5 times
State	Battery Low	TR-151 is in standby mode	TR-151 is being turned "ON".	TR-151 is being turned "OFF".	SOS button is pressed	Error occurs

Power LED

LED	Orange	Off
State	TR-151 connected to charger or USB to Mini-USB cable.	LED shuts down after battery charge completion.

4. Device Operation

4.1 Device charging

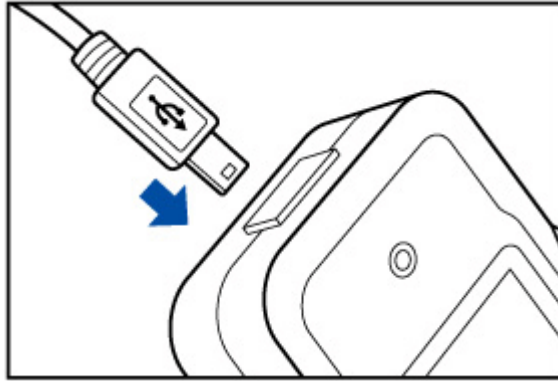

First time users, rechargeable battery requires a complete charge before using TR-151 device. Therefore, to maximize your device's battery life proceed by performing the steps listed below.

Using the AC Adapter charge method:

1. Connect TR-151 to its supplied AC power adapter cable.
2. Allow a 4 hour battery charge time. (TR-151 in power-off condition)

Using the USB cable charge method:

1. Connect TR-151 to its supplied USB to Mini-USB cable to PC or Notebook. (Computer requires to be "ON")
2. Allow a 4 hour battery charge time. (TR-151 in power-off condition)

Note: *The attached battery is specially designed for TR-151 devices. Please do not use other battery types; otherwise, it may cause permanent device damage. In effect, voiding your warranty. Please, contact your local dealer for battery replacements.*

4. Device Operation (Continued)

4.2 SIM card and Battery Installation

- Unscrew TR-151 by screwdriver.

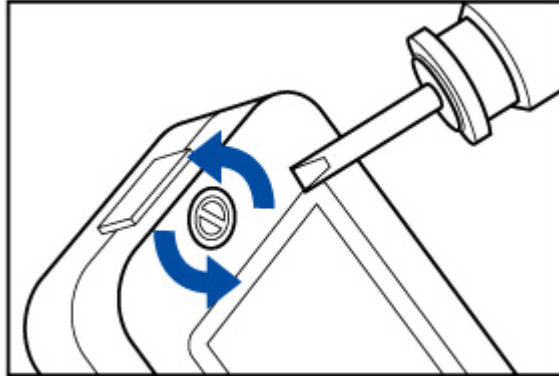

- Lift and remove the back cover.

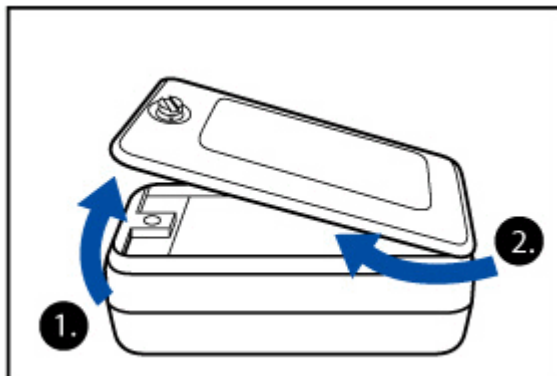

4. Device Operation (Continued)

- Push forward the SIM card slot cover to the position marked with “OPEN”. Then, lift cover up.
- Insert SIM card with its metal contacts facing down with the cut corner at position on the top left.

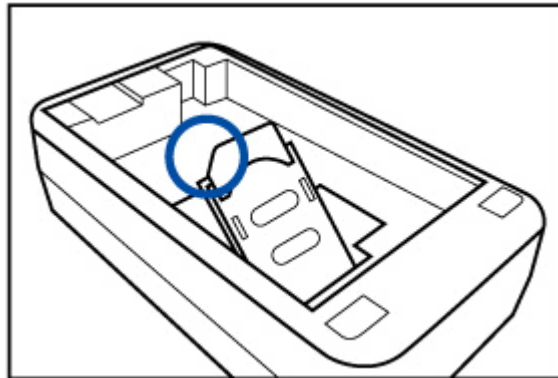

- Be certain DIP switch “3” is in “OFF” position with the sharp point object i.e., pen point.

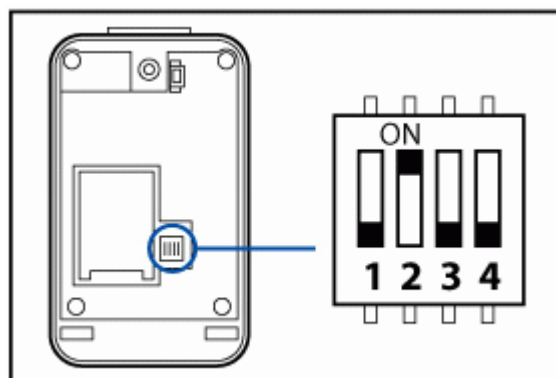

4. Device Operation (Continued)

- Connect the battery connector into the 3 pin white socket. As illustrated below, red wire orientation must be positioned next to the outer enclosure rim.

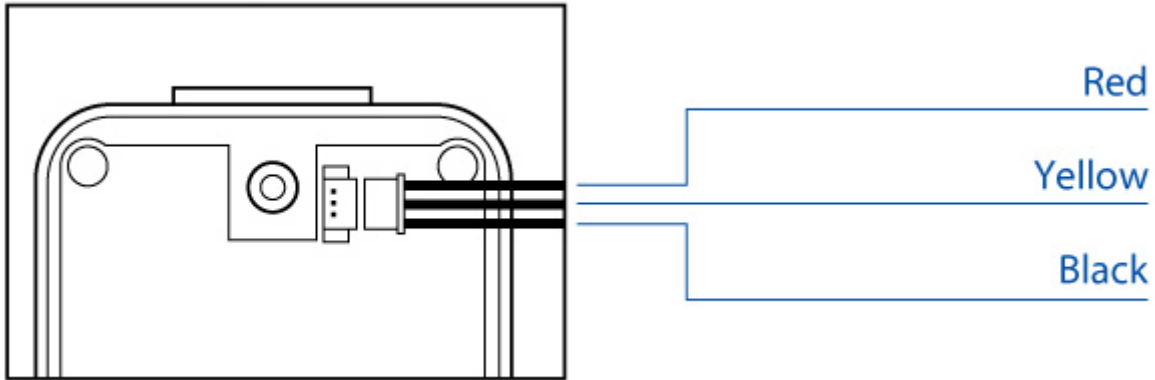

- Place battery wires under the battery, then, gently position the physical battery into the compartment.

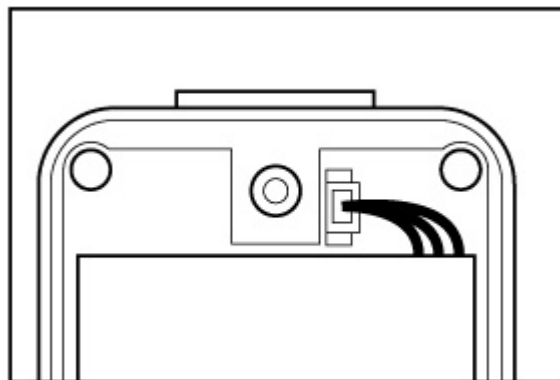

Note: After installing the battery, the status LED will emit red light. After the LED goes out, please wait for 5 seconds before turning on the power.

Note: Please take out the battery if you do not use TR-151 for a long time.

4. Device Operation (Continued)

4.3 Power

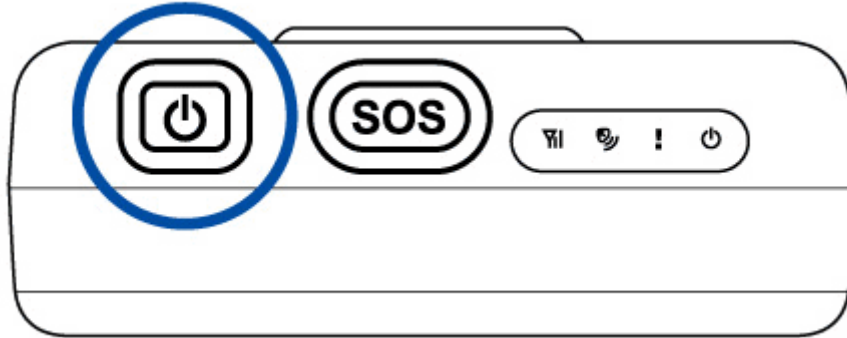

To turn the device “ON”, press and hold the power button until you see status LED ! blink 2 twice.
To turn the device “OFF”, press and hold the power button until you see status LED ! blink 1 once.

4.4 Emergency button

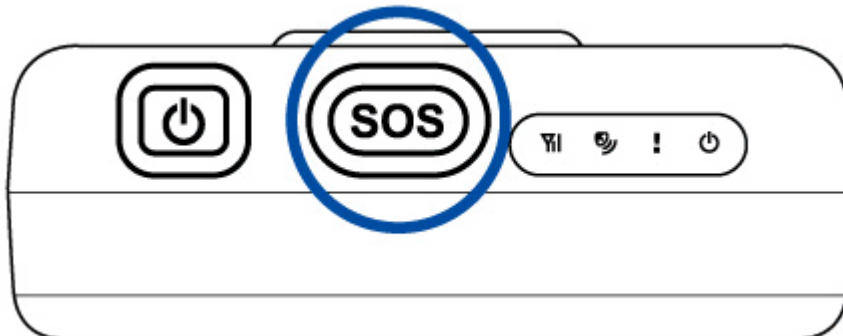

Press and hold the emergency button until you see status LED ! blink 3 times. TR-151 will attempt to receive a GPS fix, then, communicate the emergency SMS to the preset phone number.

5. Safety Information

- As for the operation of this product in the aircraft, please consult the aviation company first of all. Special care should be taken when an electronics device is engaged during a flight.
- Never get closer to a place emitting intensive radio waves or radiation which could affect the operation of this product.
- Never make the navigator fall down or clash with stiff objects to project it against any damage in appearance, battery loose, data lose or other hardware mutilation.
- Never let this product expose to the humid environment or rain as the water leaked into could disable it to the extent beyond reparation.
- Never switch on this product in the dusty environment.
- Over-voltage, power cable strain, bending or squeezing by heavy objects is not allowed to avoid overheating or fire disaster.
- Never deploy any chemical or detergent to clean up the navigator to prevent erosion of the surface or paintwork.
- In order to eliminate the risk of electric shock, do not touch the cable power plug with wet hands and do plunge it into the socket completely.
- Never charge the battery in a neither extreme cold nor hot place, which could damage the battery.
- Keep this product which is being charged out of the reach of children.
- Never put it under the direct baking sunshine or place it in a place with high temperature to avoid the problem of over-heat to the battery or this product, which could trigger fault or danger.
- When any sort of fault comes into being, please contract with qualified maintenance personnel for service rather than disassemble it at your own discretion.
- Keep all the wires in neat order to prevent damage-fostering tangling.

6. Limited Warranty

Globalsat/USGlobalsat (1) Year Limited Warranty

FOR CONSUMERS, WHO ARE COVERED BY CONSUMER PROTECTION LAWS OR REGULATIONS IN THEIR COUNTRY OF PURCHASE OR, IF DIFFERENT, IN THEIR COUNTRY OF RESIDENCE, THE BENEFITS CONFERRED BY THIS WARRANTY ARE IN ADDITION TO ALL RIGHTS AND REMEDIES CONVEYED BY SUCH CONSUMER PROTECTION LAWS AND REGULATIONS. THIS WARRANTY DOES NOT EXCLUDE, LIMIT OR SUSPEND ANY RIGHTS OF CONSUMERS ARISING OUT OF NONCONFORMITY WITH A SALES CONTRACT. SOME COUNTRIES, STATES AND PROVINCES DO NOT ALLOW THE EXCLUSION OR LIMITATION OF

INCIDENTAL OR CONSEQUENTIAL DAMAGES OR ALLOW LIMITATIONS ON HOW LONG AN IMPLIED WARRANTY OR CONDITION MAY LAST, SO THE LIMITATIONS OR EXCLUSIONS DESCRIBED BELOW MAY NOT APPLY TO YOU. THIS WARRANTY GIVES YOU SPECIFIC LEGAL RIGHTS, AND YOU MAY ALSO HAVE OTHER RIGHTS THAT VARY BY COUNTRY, STATE OR PROVIDENCE. THIS LIMITED WARRANTY IS GOVERNED BY AND CONSTRUED UNDER THE LAWS OF THE COUNTRY IN WHICH PRODUCT PURCHASE TOOK PLACE. GLOBALSAT/ USGLOBALSAT, THE WARRANTOR UNDER THIS LIMITED WARRANTY, IS IDENTIFIED AT THE END OF THIS DOCUMENT ACCORDING TO THE COUNTRY OR REGION IN WHICH THE PRODUCT PURCHASE TOOK PLACE.

Globalsat/ USGlobalsat's warranty obligations for this hardware product are limited to the terms set forth below:

Globalsat/ USGlobalsat, as defined below, warrants this hardware product against defects in materials product hardware against manufacturing defects in materials and workmanship under normal use for a period of ONE (1) year from the date of retail purchase by the original end-user purchaser and purchased from a recognized "authorized dealer" ("Warranty Period"). Products purchased from any unauthorized source, such as unauthorized e-Bay resellers, will not qualify for free warranty service/support and may require the end-user to pre-pay fees associated with, but not limited to the support, repair, replacement and shipping of the product to and from the service center. If a hardware defect arises and a valid claim is received by Globalsat/ USGlobalsat within the Warranty Period, at its option and to the extent permitted by law, Globalsat/ USGlobalsat will either (1) repair the product at no charge, using new parts or parts equivalent to new in performance and reliability, (2) exchange the product with a product that is new or equivalent to new in performance and reliability and is at least functionally equivalent to the original product or, (3) refund the purchase price of the product. Globalsat/ USGlobalsat may request that you replace defective parts with new or refurbished user-installable parts that Globalsat/ USGlobalsat provides in fulfillment of its warranty obligation. A replacement product or part, including a user-installable part that has been installed in accordance with instructions provided by Globalsat/ USGlobalsat, assumes the remaining warranty of the original product or ninety (90) days from the date of replacement or repair, whichever provides longer coverage for you. When a product or part is exchanged, any replacement item becomes your property and the replaced items becomes Globalsat/ USGlobalsat's property. Parts provide by Globalsat/ USGlobalsat in fulfillment of its warranty obligation must be used in products for which warranty service is claimed. When a refund is given, the product for which the refund is provided must be returned to Globalsat/ USGlobalsat and becomes Globalsat/ USGlobalsat's property.

If a defect arises and a valid claim is received by Globalsat/ USGlobalsat after the first one hundred and eighty (180) days of Warranty period, a shipping and handling charge may apply to any repair or exchange

of the product undertaken by Globalsat/ USGlobalsat.

EXCLUSIONS AND LIMITATIONS

This Limited Warranty applies only to the hardware product manufactured by or for Globalsat that can be identified by the “Globalsat” trademark, trade name, or logo annexed to it. The Limited Warranty does not apply to any non-Globalsat hardware product or any software, even if packaged or sold with the Globalsat hardware.

Manufacturers, suppliers, or publishers, other than Globalsat/ USGlobalsat, may provide their own warranties to the end user purchaser, but Globalsat/ USGlobalsat, in so far as permitted by law, provides their products “as-is”. Software distributed by Globalsat/ USGlobalsat with or without the Globalsat brand name (including, but not limited to system software) is not covered under this Limited Warranty. Refer to the licensing agreement accompanying the software for details of your rights with respect to its use. Globalsat/ USGlobalsat does not warrant that the operation of the product will be uninterrupted or error-free. Globalsat/ USGlobalsat is not responsible for damage arising from failure to follow instructions relating to the product’s use.

This warranty does not apply: (a) to consumable parts, such as batteries, unless damage has occurred due to a defect in materials and workmanship; (b) to cosmetic damage, including but not limited to scratches, dents, and broken plastic on ports; (c) to damage cause by use accident, abuse, misuse, flood, fire, earthquake or other external causes; (e) to damage caused by operating the product outside the permitted or intended uses described by Globalsat/ USGlobalsat; (f) to damage caused by service (including upgrades and expansions) performed by anyone who is not a representative of Globalsat/ USGlobalsat or an Globalsat/ USGlobalsat authorized service provider; (g) to a product or part that has been modified to alter functionality or capability without the written permission of Globalsat/ USGlobalsat; or (h) if any Globalsat/ USGlobalsat serial number has been removed or defaced.

IMPORTANT: Do not open the hardware product. Opening the hardware product may cause damage that is not covered by this warranty. Only Globalsat/ USGlobalsat or an authorized service provider should perform service on this hardware product.

TO THE EXTENT PERMITTED BY LAW, THIS WARRANTY AND THE REMEDIES SET FORTH ABOVE ARE EXCLUSIVE AND IN LIEU OF ALL OTHER WARRANTIES, REMEDIES AND CONDITIONS, WHETHER ORAL OR WRITTEN, STATUTORY, EXPRESS OR IMPLIED. AS PERMITTED BY APPLICABLE LAW, GLOBALSAT/ USGLOBALSAT SPECIFICALLY DISCLAIMS ANY AND ALL STATUTORY OR IMPLIED WARRANTIES, INCLUDING, WITHOUT LIMITATION, WARRANTIES OF

MERCHANTIBILITY AND FITNESS FOR A PARTICULAR PURPOSE AND WARRANTIES AGAINST HIDDEN OR LATENT DEFECTS. IF GLOBALSAT/ USGLOBALSAT CANNOT LAWFULLY DISCLAIM STATUTORY OR IMPLIED WARRANTIES THEN TO THE EXTENT PERMITTED BY LAW, ALL SUCH WARRANTIES SHALL BE LIMITED IN DURATION OF THE EXPRESS WARRANTY AND TO THE REPAIR OR REPLACEMENT SERVICE AS DETERMINED BY GLOBALSAT/ USGLOBALSAT IN ITS SOLE DISCRETION.

No Globalsat/ USGlobalsat reseller, agent, or employee is authorized to make any modifications, extension, or addition to this warranty. If any term is held to be illegal or unenforceable, the legality or enforceability of the remaining terms shall not be affected or impaired.

EXCEPT AS PROVIDED IN THIS WARRANTY AND TO THE MAXIMUM EXTENT PERMITTED BY LAW, GLOBALSAT/ USGLOBALSAT IS NOT RESPONSIBLE FOR DIRECT, SPECIAL, INCIDENTAL OR CONSEQUENTIAL DAMAGES RESULTING FROM ANY BREACH OF WARRANTY OR CONDITION, OR UNDER ANY OTHER LEGAL THEORY, INCLUDING BUT NOT LIMITED TO LOSS OF USE; LOSS OF REVENUE; LOSS OF ACTUAL OR ANTICIPATED PROFITS (INCLUDING LOSS OF PROFITS ON CONTRACTS); LOSS OF THE USE OF MONEY; LOSS OF ANTICIPATED SAVINGS; LOSS OF BUSINESS; LOSS OF OPPORTUNITY; LOSS OF GOODWILL; LOSS OF REPUTATION; LOSS OF; DAMAGE TO OR CORRUPTION OF DATA; OR ANY INDIRECT OR CONSEQUENTIAL LOSS OR DAMAGE HOWSOEVER CAUSED INCLUDING THE REPLACEMENT OF EQUIPMENT AND PROPERTY, ANY COSTS OF RECOVERING, PROGRAMMING OR REPRODUCING ANY PROGRAM OR DATA STORED IN OR USED WITH THE GLOBALSAT/ USGLOBALSAT PRODUCT AND ANY FAILURE TO MAINTAIN THE CONFIDENTIALITY OF DATA STORED ON THE PRODUCT. THE FOREGOING LIMITATION SHALL NOT APPLY TO DEATH OR PERSONAL INJURY CLAIMS, OR ANY STATUTORY LIABILITY FOR INTENTIONAL AND GROSS NEGLIGENT ACTS AND/OR OMISSIONS. GLOBALSAT/ USGLOBALSAT DISCLAIMS ANY REPRESENTATION THAT IT WILL BE ABLE TO REPAIR ANY PRODUCT UNDER THIS WARRANTY OR MAKE A PRODUCT EXCHANGE WITHOUT RISK TO OR LOSS OF PROGRAMS OR DATA.

OBTAINING WARRANTY SERVICE

Please access and review the online help resources referred to in the documentation accompanying this hardware product before seeking warranty service. If the product is still not functioning properly after making use of these resources, access the online website www.usglobalsat.com for instructions on how to obtain warranty service. You must follow Globalsat/ USGlobalsat warranty processes. Globalsat/ USGlobalsat may provide warranty service (i) by sending the unit to Globalsat/ USGlobalsat location, where service is performed at the location, or (ii) by sending the unit to an authorized Globalsat/ USGlobalsat supplier (iii) by sending you new or refurbished customer-installable replacement product or

parts to enable you to service or exchange your own product ("RMA service"). Upon receipt of the replacement product or part, the original product or part becomes the property of Globalsat/ USGlobalsat and you agree to follow instructions, including, if requires, arranging the return of the product or part to Globalsat/ USGlobalsat in a timely manner. When providing RMA service requiring the return of the original product or part, Globalsat/ USGlobalsat may require credit card authorization as security for the retail price of the replacement product or part and applicable shipping costs. If you follow the instructions, Globalsat/ USGlobalsat will cancel the credit card authorization, so you will not be charged for the product or part and shipping costs. If you fail to return the replace product or part as instructed, Globalsat/ USGlobalsat will charge the credit card for the authorized amount. Service options, parts availability and response times may vary according to the country in which service is requested. Service options are subject to change at any time. You may be responsible for shipping and handling charges if product cannot be serviced in the country in which service is requested. If you seek service in a country that is not the country of purchase, you will comply with applicable export laws and regulations and be responsible for all custom duties, V.A.T. and other associated taxes and charges. For international service, Globalsat/ USGlobalsat may repair or exchange defective products and parts with comparable products and parts that comply with local standards. In accordance with applicable law, Globalsat/ USGlobalsat may require that you furnish proof of purchase details and/ or comply with the registration requirements before receiving warranty service.

Please refer to the accompanying documentation for more details on this and other matters obtaining warranty service.

Globalsat/ USGlobalsat will maintain and use customer information in accordance with the Globalsat/ USGlobalsat Privacy Policy.

If your product is capable of storing software programs, data and other information, you should make periodic backup copies of the information contained on the product's hard drive or other storage media to protect the contents and as a precaution against possible operational failures. Before you deliver your product for warranty service it is your responsibility to keep a separate backup copy of the contents, and disable any security passwords. IT IS POSSIBLE THAT THE CONTENTS OF YOUR HARD DRIVE WILL BE LOST OR REFORMATTED IN THE COURSE OF WARRANTY SERVICE, AND GLOBALSAT/ USGLOBALSAT AND ITS AGENTS ARE NOT RESPONSIBLE FOR ANY DAMAGE TO OR LOSS OF PROGRAMS, DATA OR OTHER INFORMATION CONTAINED ON THE MEDIA OR ANY PART OF THE PRODUCT SERVICED. Your product will be returned to you configured as originally purchased, subject to applicable updates. You will be responsible for reinstalling all other software programs, data and passwords. Recovery and reinstallation of service programs and user data are not covered under this Limited Warranty.

7. FCC Notices

This equipment has been tested and found to comply with the limits for a Class B digital device, pursuant to Part 15 of the FCC Rules. These limits are designed to provide reasonable protection against harmful interference in a residential installation. This equipment utilize, exhibits and can radiate radio frequency energy and, if not installed and used in accordance with the instructions, may cause harmful interference to radio communications. However, there is no guarantee that interference will not occur in a particular installation. If this equipment does cause harmful interference to radio or television reception, which can be determined by turning the equipment off and on, the user is encouraged to try to correct the interference by one of the following measures:

- Reorient or relocate the receiving antenna.
- Increase the separation between the equipment and receiver.
- Connect the equipment into an outlet on a circuit different from that to which the receiver is connected.
- Consult the dealer or an experienced radio/TV technician for help.

FCC Caution: Any changes or modifications not expressly approved by the party responsible for compliance could void the user's authority to operate this equipment.

This device complies with Part 15 of the FCC Rules. Operation is subject to the following two conditions: (1) This device may not cause harmful interference, and (2) this device must accept any interference received, including interference that may cause undesired operation.

IMPORTANT NOTE:

Radiation Exposure Statement:

This equipment complies with FCC radiation exposure limits set forth for an uncontrolled environment. End users must follow the specific operating instructions for satisfying RF exposure compliance. To maintain compliance with FCC RF exposure compliance requirements, please follow operation instruction as documented in this manual.

This transmitter must not be co-located or operating in conjunction with any other antenna or transmitter. The availability of some specific channels and/or operational frequency bands are country dependent and are firmware programmed at the factory to match the intended destination. The firmware setting is not accessible by the end user.