

AVL Tracking System TR-600



V0.2

CONTENT

1. Introduction	3
1.1 Introduction	3
1.2 Features	3
1.3 Hardware Architecture	4
1.4 Hardware specification	5
1.5 Appearance	6
1.6 LED indicator	7
1.7 Cable description	8
1.8 Accessories	10
2 Operation	11
2.1 Install the SIM card	11
2.2 Install the GPS and GSM antenna	12
2.3 Install the Emergency button	13

1. Introduction

1.1 Introduction

TR-600 is a multi-functional and economical communication platform for vehicle positioning applications. It integrates high sensitivity GPS system and quad-band 850/900/1800/1900 MHz GSM system into a compact mechanism.

TR-600 is enclosed into a solid housing for simple installation. It provides real time GPS positions anytime and anywhere in the open sky and offers the precise position and vehicle status to back-end server or controller's cell phone to handle/ display/ calculate the necessary information. Benefits such as enhanced fleet management, improved vehicle safety, and useful emergency response are accomplished through the implementation of TR-600 system.

1.2 Features

- Build in Quad-band 850/900/1800/1900 MHz GSM system
- Build in high sensitivity GPS system
- Support AT command via SMS/ TCP/UDP
- Remote control via SMS/GPRS command
- Real-time regular GPS position feedback and vehicle status monitoring
- Build in 3 digital outputs, 3 digital inputs, ACC input, 1 analog input, 1 serial port
- Power supply for Lion battery and lead-acid battery
- Support multi geo-fence function
- OTA (On the air) firmware upgrading
- Data logger for 50,000 points
- Ignition/ Power Low/ Power Lost / Speed Limit detection alarm
- 3 LED indicators for GSM, GPS, power status
- External panic button for emergency SOS (Option)

1.3 Hardware Architecture

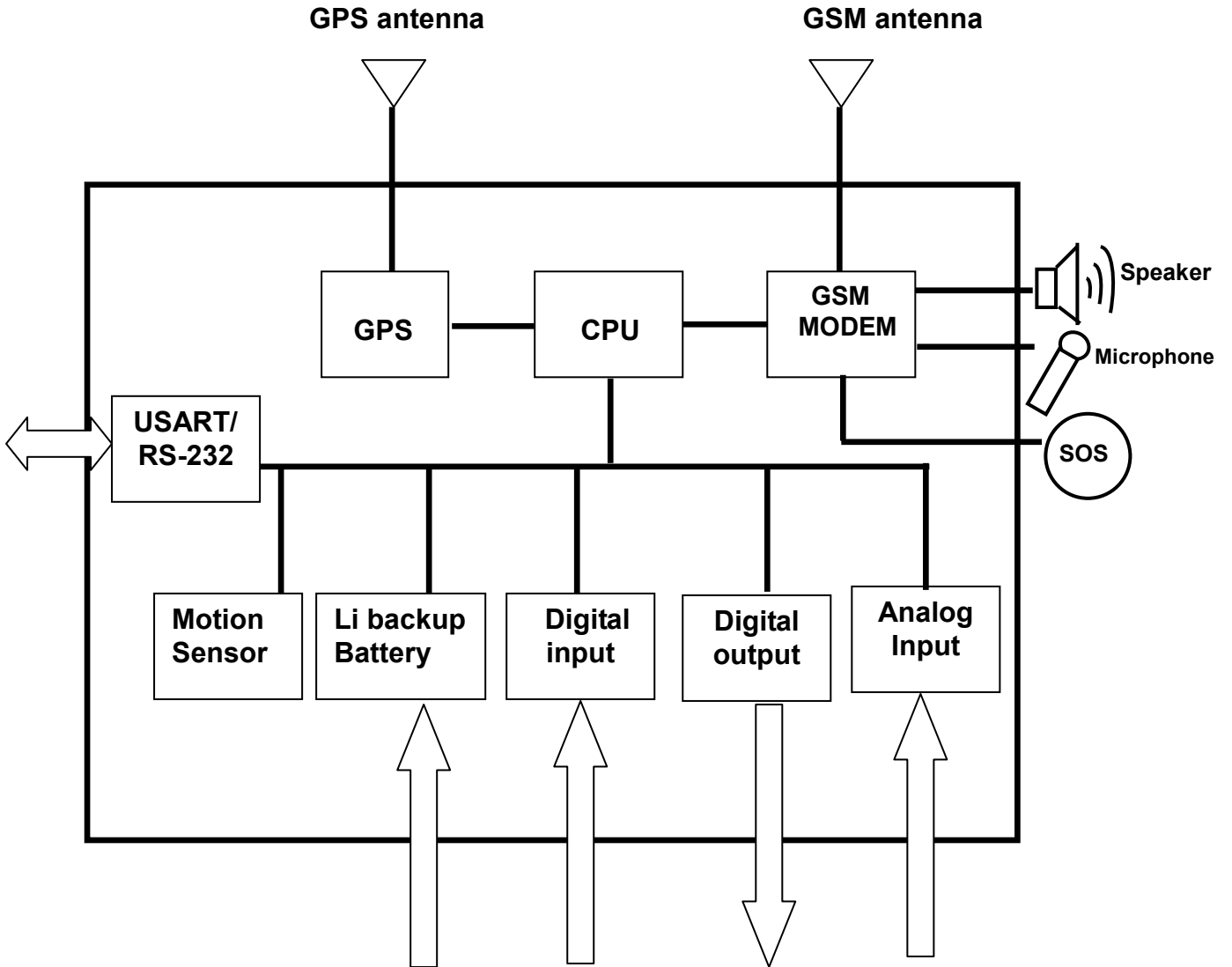

1.4 Hardware specification

Item	Description	
Dimension	98 mm X 65 mm X 22 mm	
CPU	High performance line ARM-base 32-bit MCU	
GPS receiver	SiRF Star III high performance GPS chipset	
Temperature	Operation	-30°C ~ + 80°C
	Storage	-40°C ~ + 85°C
GPS Antenna	SMA Type connector Active antenna (3.3~3.8V)	
GSM Antenna	SMA Type connector	
Communication	Telit (GE865) Quad-band GSM 850/900/1800/1900 MHz	
Protocol	Voice/SMS/GPRS (TCP/UDP/HTTP)	
Built-in Memory	32 Mb	
GPS logging capacity	50,000 points	
Emergency Input	Negative trigger	1
Ignition (ACC) Input	Positive trigger	1
Digital Input Port	Negative trigger	2
	Positive trigger	1
Digital Output Port	Negative trigger	3 (300 mA)
Analog Input Port	Analog Input	1(0~28V)
Serial Port	115200 bps	
Backup battery (Option)	Internal 800 mAh Lion battery Support external Lead-acid battery (12V/24V)	
Hands-free Kit (Option)	Support external speaker and microphone	
Sensor	Temperature sensor (Option)	
	Motion sensor	
	G-sensor (3-Axis Accelerometer) (Option)	
Function (Custom-made)	Support barcode reader	
	Support NMEA-0183 output for navigation	
	Support RFID reader	
	Support tire pressure monitoring system	

1.5 Appearance

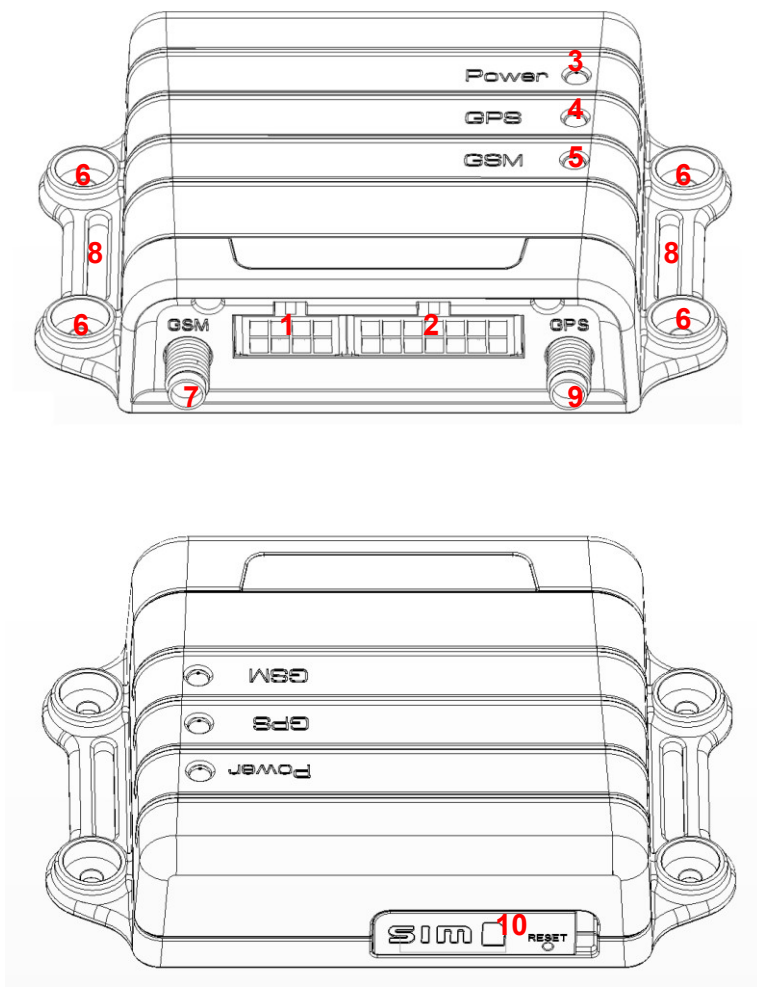

1	Peripheral interface port
2	I/O port
3	Power Status LED
4	GPS LED
5	GSM LED
6	For fixing device with screws
7	GSM antenna connector
8	For fixing device with belt
9	GPS antenna connector
10	SIM card holder

1.6 LED indicator

Power Status LED (Red)

LED	Permanently On
State	Main power on, device on

GPS LED (Yellow)

LED	Permanently off	Fast blinking (Once every 1 second)	Slow blinking (Once every 3 seconds)
State	GPS off	GPS not fix	GPS fix

GSM LED (Green)

LED	Permanently off	Fast blinking (Once every 1 second)	Slow blinking (Once every 3 seconds)
State	GSM off	<ol style="list-style-type: none">1. TR-600 is searching GSM network2. SIM card is registering to GSM network	TR-600 is registered full service

1.7 Cable description

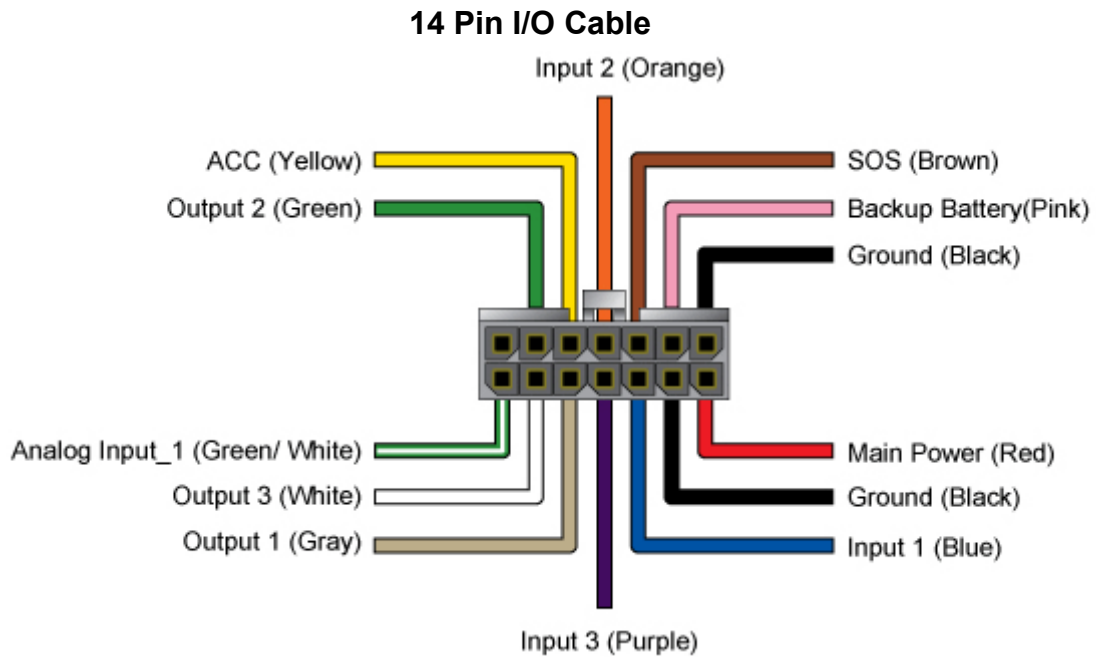

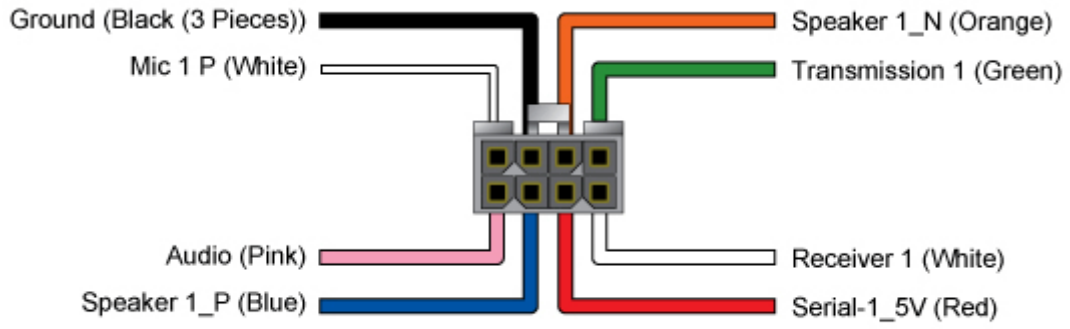

Wire Color	Description
Green/ White	Analog Input_1
White	Digital Output 3 (Negative Trigger)
Gray	Digital Output 1 (Negative Trigger)
Purple	Digital Input 3 (Positive Trigger)
Blue	Digital Input 1 (Negative Trigger)
Black	Ground
Red	Main Power
Green	Digital Output 2 (Negative Trigger)
Yellow	ACC (Positive Trigger)
Orange	Digital Input 2 (Negative Trigger)
Brown	SOS (Negative Trigger)
Pink	12V/24V Backup Battery
Black	Ground

8 Pin Cable

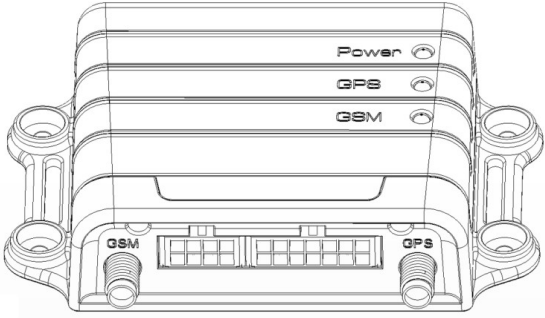
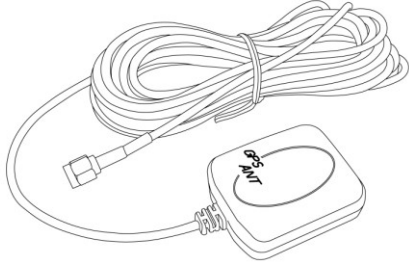
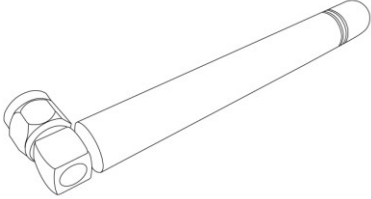
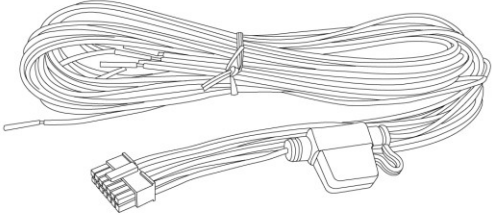

Wire Color	Description
Pink	Audio_5V
Blue	Speaker 1(Positive)
Red	Serial-1_5V
White	Receiver 1
White	Microphone 1 P
Black (3 Pieces)	Ground
Orange	Speaker 1(Negative)
Green	Transmission 1

1.8 Accessories

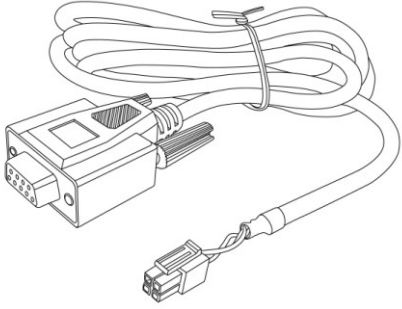
 <p>A line drawing of a rectangular main unit with a rack-like structure. It features three horizontal slots at the top labeled 'Power', 'GPS', and 'GSM'. On the front panel, there are two 'GSM' ports on the left and right sides, and a central multi-pin connector. The unit is supported by four mounting brackets, one on each side.</p>	 <p>A line drawing of a GPS antenna. It consists of a small, square-shaped antenna module with a cable attached. The cable has a standard connector at one end and a specialized connector at the other.</p>
 <p>A line drawing of a GSM antenna. It is a long, thin, cylindrical antenna with a connector at one end.</p>	 <p>A line drawing of a 14-pin I/O cable. It has a multi-pin connector at one end and a specialized connector at the other.</p>
 <p>A line drawing of an 8-pin cable. It has a multi-pin connector at one end and a specialized connector at the other.</p>	 <p>A line drawing of an RS-232 cable. It has a multi-pin connector at one end and a specialized connector at the other.</p>

2 Operation

For first time users, please follow the steps below to complete the pre-installation.

2.1 Install the SIM card



With the copper contacts face-up, align the notch on the SIM card with the notch on the SIM slot and insert the SIM card. If SIM is inserted correctly, you will not be able to see the copper contacts after inserting the card. To eject SIM card, simply, use your finger nail and apply slight pressure.

Note: Refer to your mobile phone manual to disable the SIM PIN entry function by your mobile phone.

Note: Before installing or taking out SIM card, please power off TR-600.

2.2 Install the GPS and GSM antenna



Install the GSM antenna to the GSM antenna connector on the left part of the back side and GPS antenna to the GPS antenna connector on the right part of the back side tightly. Please refer to the photo above.

2.3 Install the Emergency button

There is a line of the 14 pin IO cable for connecting push button for emergency help.

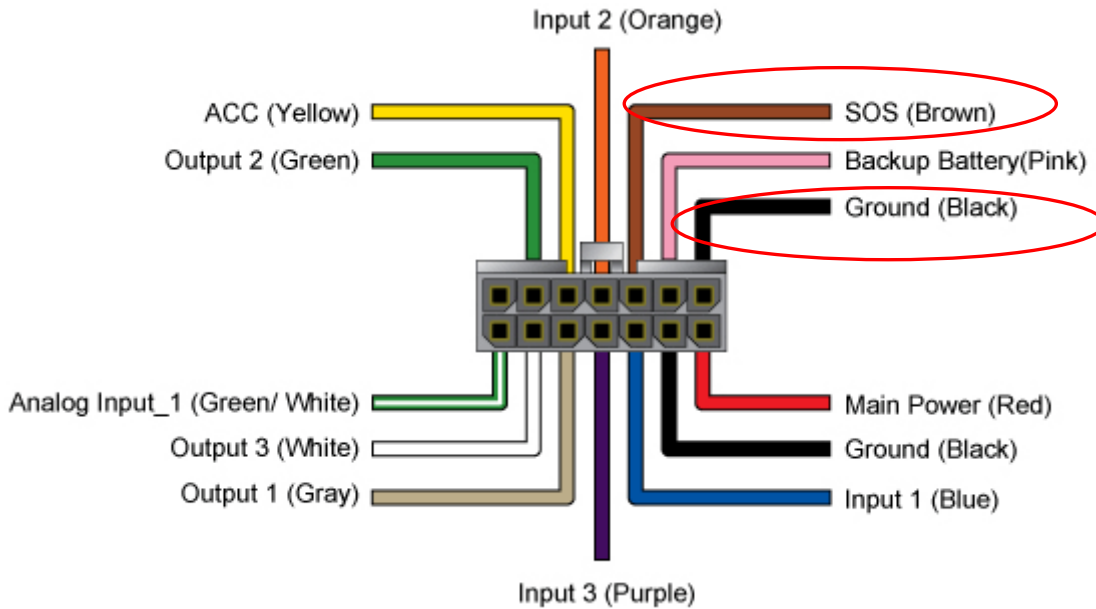

One end of the button must be connected to the SOS line and the other end must be connected to the ground line.

